

ACCESS ROAD PLAN VIEW

SCALE: 1" = 50'

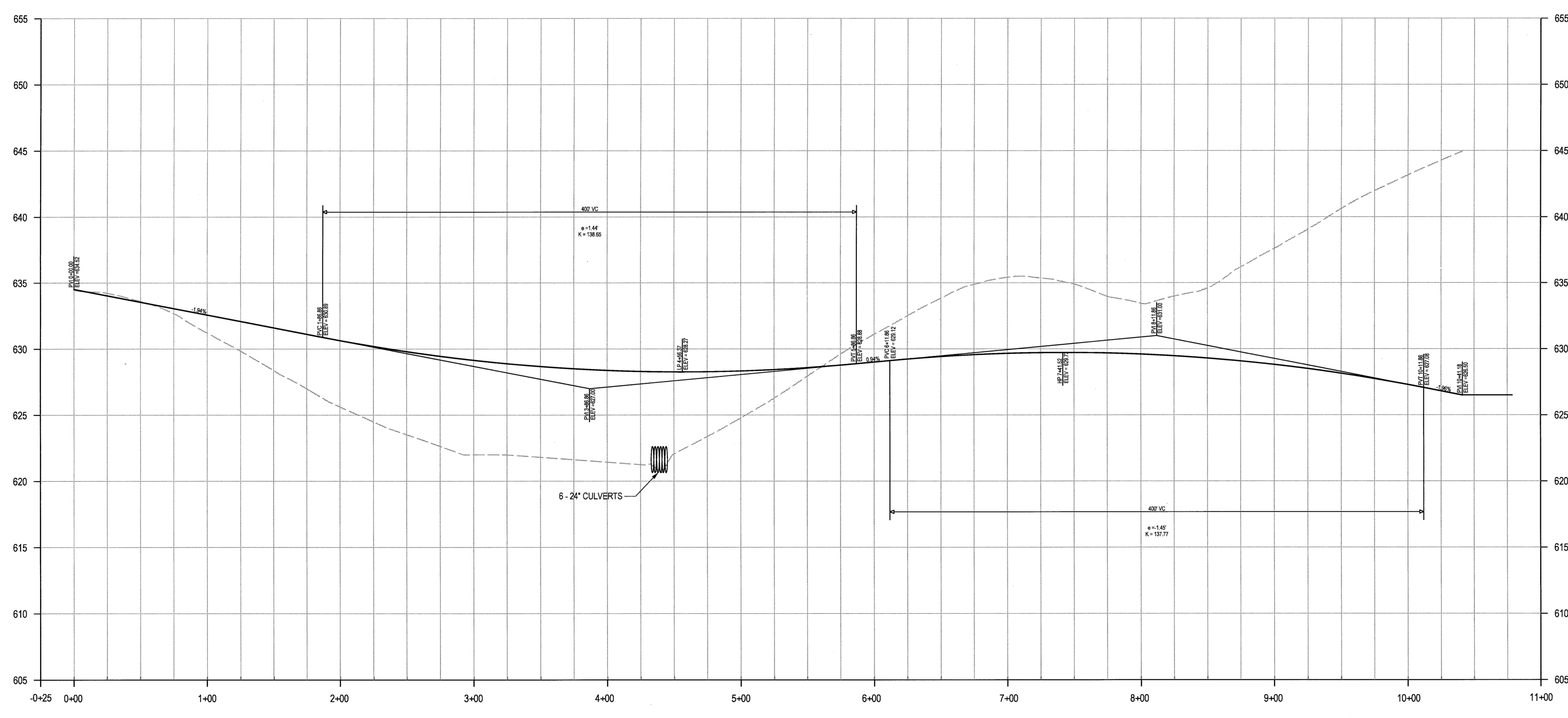

ACCESS ROAD PROFILE

SCALE: H: 1" = 50'
V: 1" = 5'

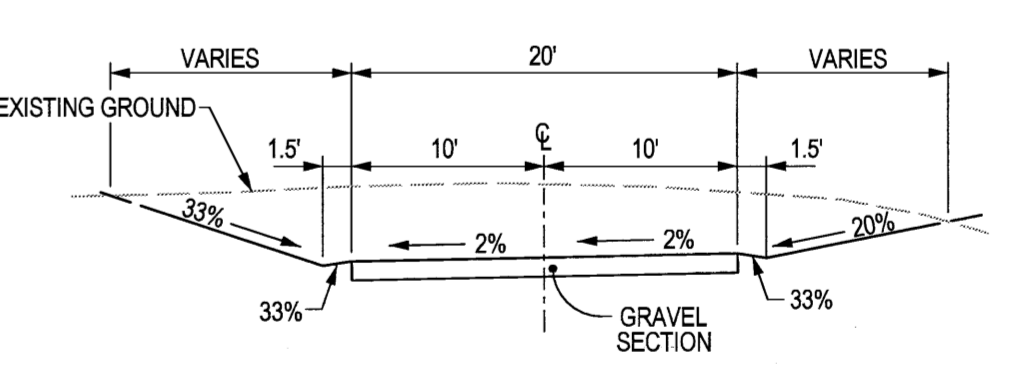
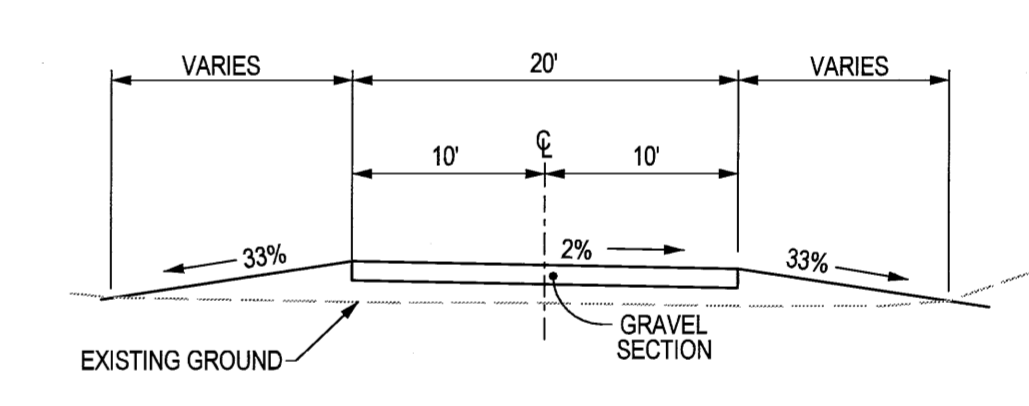
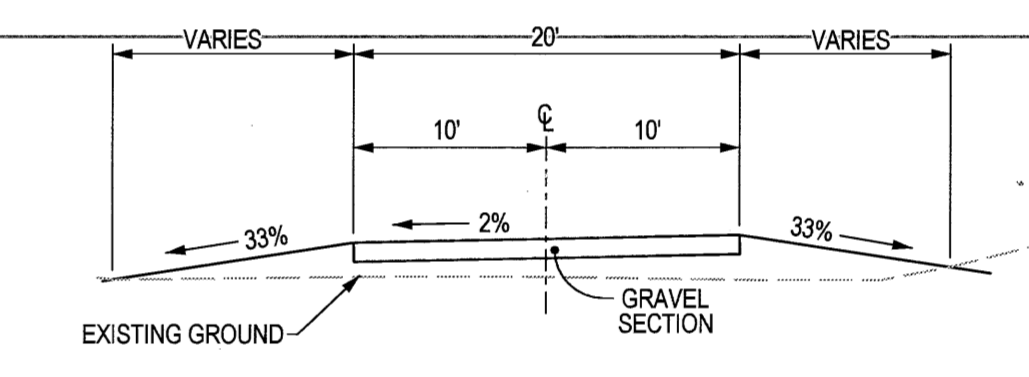

ACCESS ROAD SECTIONS

N.T.S.

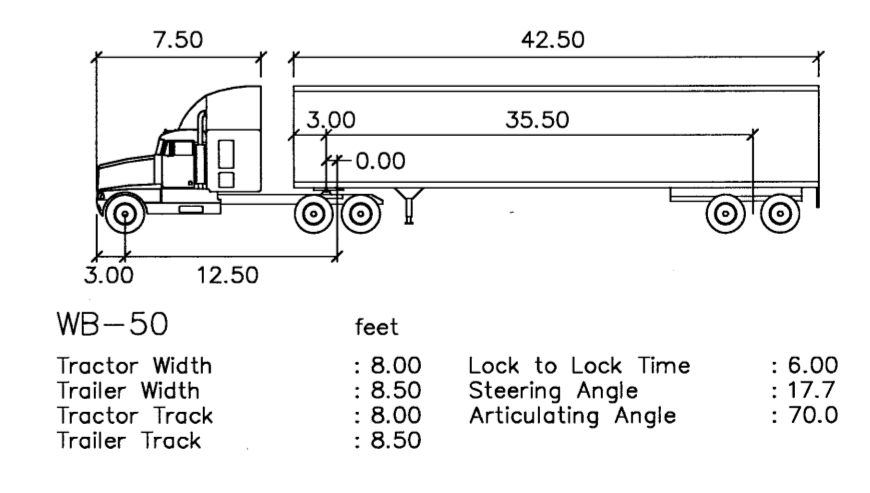

TURNING TEMPLATE INFORMATION

N.T.S.



LS Liederman Soltesz Associates, Inc.
 Rockville Office
 2 Research Place, Suite 100
 Rockville, MD 20850
 t. 301.948.2750 f. 301.948.9067
 www.LSAssociates.net

NO.	DATE	REVISIONS	BY	DATE
1	AUGUST 2010			

DESIGNER: G.P. CAD STANDARDS VERSION: 08 - 2009
 TECHNICIAN: G.M.M. CHECKED: K.C.R.

MISS UTILITY NOTE
 INFORMATION CONCERNING EXISTING UNDERGROUND UTILITIES WAS OBTAINED FROM AVAILABLE RECORDS. THE CONTRACTOR MUST DETERMINE THE EXACT LOCATION AND ELEVATION OF ALL EXISTING UTILITIES AND UTILITY CROSSINGS BY DIGGING TEST PITS BY HAND, WELL IN ADVANCE OF THE START OF EXCAVATION. CONTACT "MISS UTILITY" AT 1-800-291-7777 48 HOURS PRIOR TO THE START OF EXCAVATION. IF CLEARANCES ARE LESS THAN SHOWN ON THIS PLAN OR THIRTY (30) INCHES, WHOEVER IS LESS, CONTACT THE ENGINEER AND THE UTILITY COMPANY BEFORE PROCEEDING WITH CONSTRUCTION. CLEARANCES LESS THAN NOTED MAY REQUIRE REVISIONS TO THIS PLAN.

PREPARED FOR:
 KENNY CONSTRUCTION COMPANY
 12516 CONAMAR DRIVE
 SUITE #204 / SUITE # 205
 HAGERSTOWN, MARYLAND 21742
 PHONE: 301-745-9885
 FAX: 301-745-3038
 ATTN: MR. ROBERT DAHLIN

TAX MAP	4689	GRID	C3, C4, D3, D4
ZONING CATEGORY:	'A'		
WSBC 2007 SHEET			
SITE DATUM			
HORIZONTAL: NAD 83			
VERTICAL: NAD 83			

ACCESS ROAD EXHIBIT

KEMPTOWN SUBSTATION

SITUATED AT THE INTERSECTION OF BARTHOLOWS ROAD AND WEST OAK DRIVE
 NEW MARKET ELECTION DISTRICT No. 9
 FREDERICK COUNTY, MARYLAND

LS

SHEET **10** OF **23**

PROJECT NO. 1814-00-00